

sig pro™



sig pro™



SIG PRO SPC 2009
SIG PRO SP 2009
SIG PRO SP 2340

GB Handling and Safety
Instructions

Table of Contents

1	General Instructions	GB 2	8	Function of the Pistol	GB 21
2	Safety Regulations	GB 3	8.1	Function sequence when loading	GB 21
3	Product Description	GB 4	8.1.1	Magazine inserted	GB 21
3.1	Main parts	GB 4	8.1.2	Function sequence when loading	GB 22
3.2	Main features	GB 5	8.2	Function sequence when decocking	GB 23
3.3	Scope of supply	GB 5	8.2.1	Hammer decocking	GB 23
4	Transporting the Pistol	GB 6	8.3	Function sequence when firing in "Double Action" mode	GB 24
5	Handling the Pistol	GB 6	8.3.1	Hammer cocking with the trigger	GB 24
5.1	General remarks	GB 6	8.3.2	Firing the pistol	GB 25
5.2	Initial preparation	GB 6	8.3.3	Function sequence at shot discharge	GB 26
5.3	Ammunition	GB 6	8.4	Function sequence at case ejection and automatic reloading	GB 27
5.4	Loading the magazine	GB 7	8.4.1	Unlocking	GB 27
5.5	Loading the pistol (ready to fire)	GB 7	8.4.2	Function sequence at case ejection and hammer cocking	GB 28
5.6	Discharging a shot	GB 8	8.5	Function sequence when firing in "Single Action" mode	GB 29
5.7	Reloading during shooting	GB 9	8.6	Function sequence after discharge of last round	GB 30
5.8	Unloading the pistol	GB 9	9	Pistol Service and Repairs	GB 31
5.8.1	Unloading the pistol, magazine not empty	GB 9	9.1	Cause and correction of malfunctions	GB 31
5.8.2	Unloading the pistol, magazine empty, slide open	GB 10	9.2	Safekeeping and storage of the pistol	GB 32
6	Sight Correction	GB 11	9.3	Shipping the pistol	GB 32
6.1	Sight correction for windage	GB 11	10	Training Aids and Product Line	GB 34
6.2	Sight correction for elevation	GB 11	10.1	Training aids	GB 34
6.3	Rear and front sight variants	GB 12	10.2	Product line	GB 34
6.4	Rear and front sight keys	GB 12	11	Disposal	GB 34
7	Maintenance of the Pistol	GB 13	12	Technical Specifications / Types / Accessories	GB 35
7.1	Stripping the pistol	GB 13	12.1	SPC 2009 / SP 2009 / SP 2340	GB 35
7.2	Cleaning the pistol	GB 16	13	Spare Parts List	GB 36
7.3	Assembling the pistol	GB 18	13.1	SP 2009 / SP 2340	GB 37
7.4	Verification of functions	GB 18			
7.5	Care of the pistol	GB 20			

GB

1 General Instructions

Be sure to read through these instructions carefully before any manipulation on this *sig pro*™ pistol.

Understanding these instructions and the technically correct implementation of the information contained therein are **imperative** to correct preparation and safety during handling, care and maintenance of this *sig pro*™ pistol. Do not use the pistol until you have fully understood all safety instructions and its handling procedures. Should you require further information, do not hesitate to contact your dealer, importer or the manufacturer.

Please observe all local and national legislation governing the ownership, carrying and use of firearms.

Be aware that these pistols, like all firearms, are dangerous. Consequently, the pistol accompanying these Handling and Safety Instructions has been sold under the express understanding that the manufacturer and the importer of the pistol decline any responsibility for consequences of manipulations with or on the pistol. This applies in particular to liability for bodily harm or damage to property resulting in whole or in part from:

- discharge with criminal intent or through negligence,
- improper or careless handling,

- defective, incorrect, hand-loaded or reloaded ammunition,
- inadequate care of the pistol (e.g. corrosion, damage),
- disregard of malfunctions,
- resale in contradiction of regional legislation,
- other circumstances beyond our direct and immediate control.

These limitations apply regardless of whether liability is asserted on the basis of contract, negligence or strict liability (including any failure to warn).

The manufacturer and the importers are not liable for incidental or consequential damages such as loss of use of property, commercial loss or loss of earnings and profits.

2 Safety Regulations

- ▲ Never use the pistol when under the influence of alcohol or drugs, during illness or other complaints; they can influence your judgement and reflexes.
- ▲ Always consider the pistol as loaded and unsafe until you have verified that it is not through the unloading procedure (see Sect. 5.8).
- ▲ During all manipulations, keep the muzzle of the pistol pointed in a safe direction. Safe directions are defined as areas where there are no people, other living creatures or other people's property.
- ▲ Never point the pistol at doors, window panes, walls, concrete, stones or other flat surfaces (including water). Shots can penetrate such surfaces, or be deflected into unsafe directions by them.
- ▲ Never aim at yourself or other living creatures.
- ▲ Never rely on safety mechanisms. They are never a substitute for careful and correct handling of the pistol.
- ▲ Always handle your pistol as if the safety mechanisms were defective. The best safety device is correct, well-exercised and secure handling of the pistol.
- ▲ Never shoot a pistol into which there has been ingress of water, sand, dirt or other foreign bodies.
- ▲ Never decock the hammer by restraining the hammer and simultaneously pulling the trigger.
- ▲ Never let a loaded pistol out of your hands.
- ▲ Always unload the pistol immediately after shooting, before putting it down, holstering it or handing it to another authorized person.

- ▲ Never hand over the pistol to any person who has not thoroughly familiarized himself or herself with the safety regulations and handling of the pistol by reading the accompanying instructions.
- ▲ Never leave the pistol unattended. Unauthorized persons could cause damage with it, threaten or kill other people, for which you could be held liable.
- ▲ Never store the pistol loaded, but remove the magazine and verify that there is no round in the barrel chamber by following the unloading procedure (see Sect. 5.8).
- ▲ Always keep the pistol and the ammunition in different places and ensure that neither can fall into the hands of unauthorized persons or children.

In the individual sections of these instructions, the following safety indications alert you to various risks:



Warning

Information on risks which, if not scrupulously observed, can directly lead to severe bodily harm or death.



Caution

Information on risks which, if not scrupulously observed, can lead to bodily harm, damage to property and damage to the pistol.



Notice

Information on technical requirements which, if not scrupulously observed, can lead to damage to the pistol.

3 Product Description

3.1 Main parts

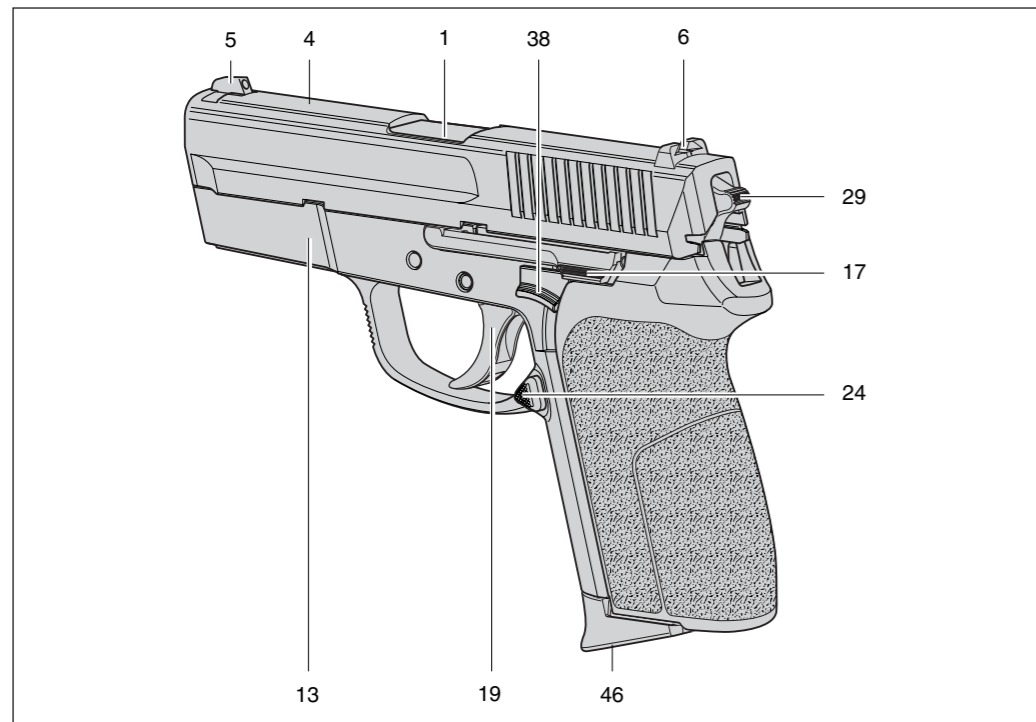

- 1 Barrel
- 4 Slide
- 5 Front sight
- 6 Rear sight
- 13 Frame
- 17 Slide catch lever
- 19 Trigger
- 24 Magazine catch
- 29* Hammer
- 38 Decocking lever
- 46 Magazine
- * See section 12 for alternative versions

Fig. 1

3.2 Main features

sig pro™ pistols are modern hand weapons complying with the latest technical advances in weapon design for military, police and sporting use. They operate on the principle of the mechanically locked, recoil-operated pistol with semi-automatic reloading. The automatic firing pin safety lock, safety notch on the hammer, decocking lever and the double-action trigger ensure safe carrying of the weapon and permanent, rapid firing readiness without actuating a manual safety lock. The decocking lever permits safe unlocking of the hammer in the safety notch without operation of the trigger. The firing pin remains locked during decocking by the automatic firing pin safety device. The distinctive contrast sights in conjunction with the ergonomically favourable grip design permit rapid, precision target acquisition and firing. The enclosed design prevents the penetration of dirt inside the weapon.

sig pro™ pistols are available as Double-Action/Single-Action (DA/SA) as well as Double-Action-Only (DAO) models. The DAO version has no decocking lever **38**. This difference is described in detail in sections 8 "Function of pistol" and 5 "Handling of pistol".

3.3 Scope of supply

- Included:
- 1 Pistol
 - 1 Magazine
 - 1 Handling and Safety Instructions
- Not included:
- Accessories (see Sect. 12)
 - Training aids (see Sect. 10.1)
 - Spare parts (see Sect. 13)

4 Transporting the Pistol



Warning

- ▲ For your own safety and for the safety of others, always transport the pistol in the **unloaded condition, decocked and under lock** (see Sect. 5.8).
- ▲ Never carry the pistol on your person with a round in the chamber and the hammer cocked.
- ▲ Always carry the pistol in such a manner that, should you fall or otherwise slip, you are able to control the direction of the muzzle.
- ▲ Transport the pistol separate from the ammunition.
- ▲ Ensure that you comply with all regional and national laws relating to the transport of firearms.

5 Handling the Pistol

5.1 General remarks

For preservation, the pistol is normally delivered with a light coating of protective grease and oils. Before initial preparation, the pistol must be stripped, the protective coatings removed and then relubricated.

5.2 Initial preparation

Procedure

1. Strip the pistol (see Sect. 7.1)
2. Clean and relubricate the pistol (see Sect. 7.2)
3. Assemble the pistol (see Sect. 7.3)

5.3 Ammunition



Warning

- ▲ For your pistol, use only commercial grade ammunition in the original packaging, which corresponds to the calibre of the pistol. The correct calibre is stamped on the pistol.
- ▲ Never use reloaded, “refurbished”, hand-loaded, non-standard ammunition, or ammunition of a different calibre.
- ▲ Never use dirty, wet, corroded, bent, damaged or oiled ammunition.
- ▲ Never leave ammunition unattended.

5.4 Loading the magazine

Procedure

1. Place round on feeder **49**, close to the magazine lips.
2. Press round down and slip it to the rear.
3. Load the number of rounds that you intend to shoot.

Number of inserted rounds can be checked through the holes of the magazine.

5.5 Loading the pistol (ready to fire)



Warning

- ▲ Never load or unload the pistol inside a vehicle, inside a building or other confined space (except in a designated firing range).
- ▲ Before loading, always wipe off any excess grease and oil and check that there is no obstruction in the bore of the barrel **1**.
- ▲ Always keep the muzzle of the pistol pointed in a safe direction.
- ▲ Do not place your finger on trigger **19**, but outside of the trigger guard.
- ▲ Do not load the pistol by inserting the magazine until immediately before shooting.

- ▲ Never directly draw back hammer **29** by hand in order to cock it.
- ▲ Never rely on safety mechanisms. They are never a substitute for careful and correct handling of the pistol.
- ▲ Never let a loaded pistol out of your hands.

Procedure

1. Point the pistol in a safe direction.
2. Insert full magazine **46** and check that it engages.
3. Draw back slide **4** to the stop and allow it to fly forward.
 - The pistol is loaded and ready to fire with the single action trigger.
 - The pistol can then be decocked with decocking lever **38**. Now the pistol is loaded, decocked and ready to fire with the double action trigger.
 - The Double Action Only (DAO) pistol is decocked and ready to fire.



Notice

- ▲ Double Action Only (DAO) pistols do not have a decocking lever **38**. With each cocking or reloading, the hammer **29 C** is caught by the hammer safety notch.

5.6 Discharging a shot



Warning

- ▲ Ensure that the target and the environment allow shots to be fired without danger.
- ▲ When discharging shots, ensure that neither your fingers, hands or any other part of the body are located in front of, adjacent to, or over the barrel muzzle or the ejector port.
- ▲ Never allow other persons to stand beside you where they might be struck by ejected cartridge cases.
- ▲ Always wear ear protection and safety glasses when shooting. Alert bystanders to the importance of wearing ear protection.
- ▲ Immediately stop shooting and unload the pistol (see Sect. 9.1) if you suspect that a round has not been chambered properly, a case is jammed, a bullet is lodged in the bore, or a discharge sounded or felt weak or abnormal.
- ▲ Never attempt to dislodge a blockage by firing another round.

Procedure

1. Aim the pistol at a safe target.
2. Place finger on trigger **19** and pull back trigger **19** to discharge the shot.
3. Keep the pistol aimed at the target and fire further shots as required.
4. Remove magazine and unload the pistol (see Sect. 5.8). If the pistol has been fired until the magazine is empty, slide **4** will be caught in the open position. If firing is to continue, reload the pistol (see Sect. 5.7).



Warning

- ▲ After each discharge, Double Action/Single Action pistols are in the cocked and ready to fire condition.
- ▲ If you wish to interrupt the shooting session, you must actuate decocking lever * **38**. The pistol is then in the loaded, decocked and ready to fire condition.
- ▲ After each discharge, Double Action Only (DAO) pistols are in the decocked condition and ready to fire with the double action trigger.

* Not applicable to DAO pistols.

5.7 Reloading during shooting

The slide is caught in the open position.



Warning

- ▲ Never let the pistol out of your hands.
- ▲ Keep the pistol pointed at the safe target.

Procedure

1. Remove the empty magazine.
2. Insert full magazine and ensure that it engages.
3. Thumb down slide catch lever **17** or draw back slide **4** to the stop and allow it to fly forward (see Sect. 5.5).
 - The pistol is loaded and ready to fire.
 - The pistol can also be decocked with decocking lever **38**. (Not applicable to DAO pistols.)
 - The pistol is now loaded, decocked and ready to fire.

5.8 Unloading the pistol

5.8.1 Unloading the pistol, magazine not empty



Warning

- ▲ Never let the pistol out of your hands before it is unloaded.
- ▲ The pistol is loaded, a round is located in the chamber of the barrel.

- ▲ Execute the unloading cycle with only two fingers from the rear.
- ▲ Never place your hand over the ejection port of the slide.

Procedure

1. Keep the muzzle of the pistol pointed in a safe direction.
2. On Double Action/Single Action pistols, actuate decocking lever **38**; hammer **29** will catch in the hammer safety notch. With Double Action Only (DAO) pistols, hammer **29 C** automatically registers in the hammer safety notch.
3. Actuate magazine catch **24** and remove the magazine (Fig. 2).

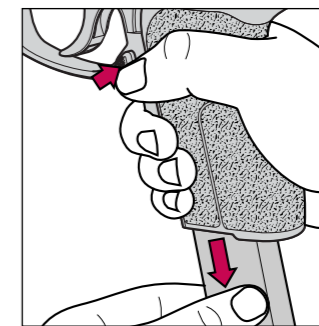

Fig. 2

Handling the Pistol

4. Draw back slide **4** to the stop and thumb up slide catch lever **17**. The round will be ejected and slide **4** caught in its open position.
5. Check visually, and manually with a tool, that the round was ejected and that no other round is chambered (Fig. 3).
6. Actuate slide catch lever **17**. Slide **4** will be impelled forward.
7. Thumb down decocking lever **38**. (Not applicable to DAO pistols.)
8. Empty magazine.
9. Pick up and clean ejected round.

The pistol is unloaded and decocked. It must be cleaned after every shooting session (see Sect. 7).

5.8.2 Unloading the pistol, magazine empty, slide open



Warning

- ▲ The pistol must not be put down and out of your hand until the magazine is removed and the pistol is unloaded.

Procedure

1. Keep the muzzle of the pistol pointed in a safe direction.
2. Actuate magazine catch **24** and remove the magazine (see Fig. 2, page 9).
3. Check that no round is chambered (visually and manually with an aid) (Fig. 3).

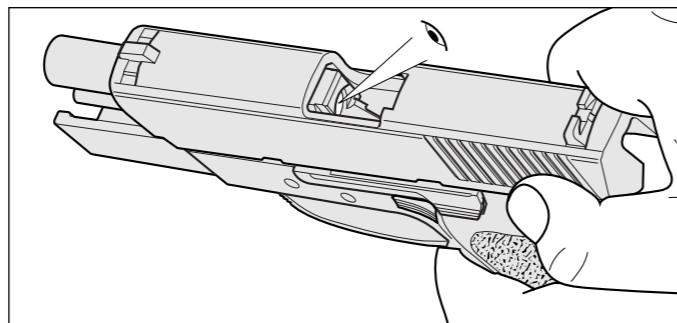

Fig. 3

4. Actuate slide catch lever **17**. Slide **4** will be impelled forward.
5. Thumb down decocking lever **38**. (Not applicable to DAO pistols.)

The pistol is unloaded and decocked.

Sights

6 Sight Correction

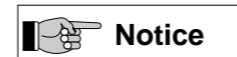

Notice

▲ Any adjustment to sights should only be done on an unloaded pistol, by an armorer, gunsmith or other qualified person. Special tools (see Sect. 6.4) are required for this task. Corrections should first be made to rear sight **6**.

6.1 Sight correction for windage

Shifting the rear sight **6**

Shifting the rear sight **6** by 0.5 mm to the right alters the point of impact by 8.4 cm to the right at 25 m range.

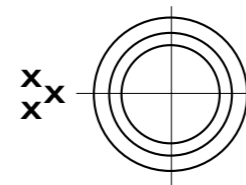

Fig. 4,
point of impact left

Shifting the front sight **5**

Shifting the front sight **5** by 0.5 mm to the left alters the point of impact by 8.4 cm to the right at 25 m range.

6.2 Sight correction for elevation

Changing the rear sight **6**

Changing the rear sight **6** for a lower one (one rear sight increment) alters the point of impact by 4.6 cm lower at 25 m range.

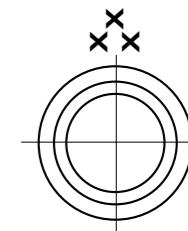

Fig. 5,
point of impact high

Changing the front sight **5**

Changing the front sight **5** for a higher one (one front sight increment) alters the point of impact by 2.3 cm lower at 25 m range.

6.3 Rear and front sight variants

Rear sight variants

Number	04	05	06	07	08	09	10
Height	5.24 mm	5.52 mm	5.80 mm	6.07 mm	6.35 mm	6.62 mm	6.90 mm

Front sight variants

Number	05	06	07	08	09	10
Height	6.01 mm	5.88 mm	5.74 mm	5.60 mm	5.46 mm	5.32 mm

6.4 Rear and front sight keys

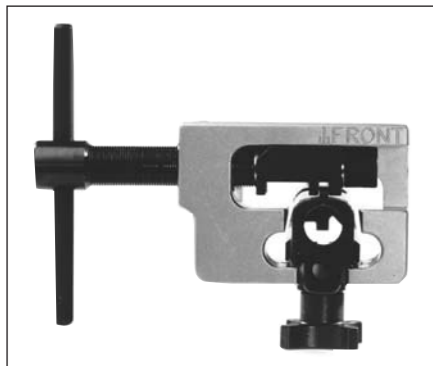

Fig. 6, Combined rear and front sight key, from front

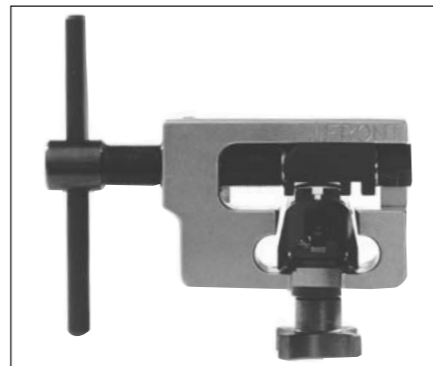

Fig. 7, Combined rear and front sight key, from rear

7 Maintenance of the Pistol



Warning

- ▲ The magazine must be removed from the pistol.
- ▲ Before stripping your pistol for cleaning, ensure once again that it is unloaded (see Sect. 5.8).
- ▲ Do not grasp slide 4 with your fingers.

7.1 Stripping the pistol

1. Unload the pistol (see Sect. 5.8).
2. Draw back slide 4 to the stop and arrest it in the open position by thumbing up slide catch lever 17 (Fig. 8).

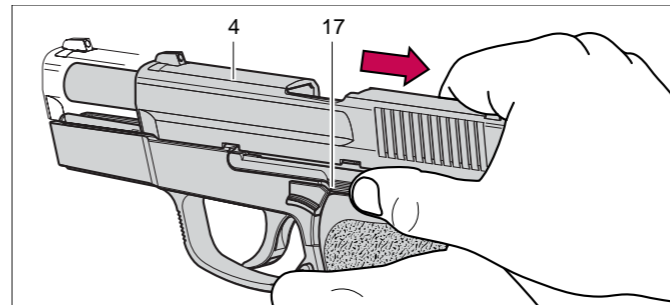

Fig. 8

3. Check that no round is chambered (see Fig. 3, page 10).
4. Take the frame and slide in your right hand. Pull the slide 4 back slightly to release the slide catch lever 17. Then allow the slide 4 to move forwards by about 3 mm until the recess 4b on the slide 4 rests with its tip against the slide catch lever 17. Press the slide catch lever 17 in from the right and remove from the left (Fig. 9).

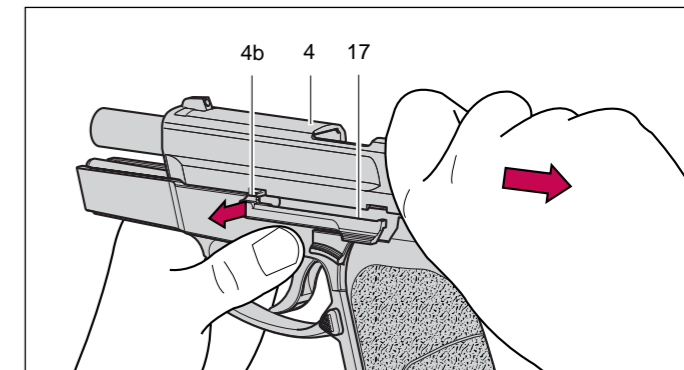

Fig. 9

5. Follow the slide **4** forwards with your hand until the recoil spring **3** is released.

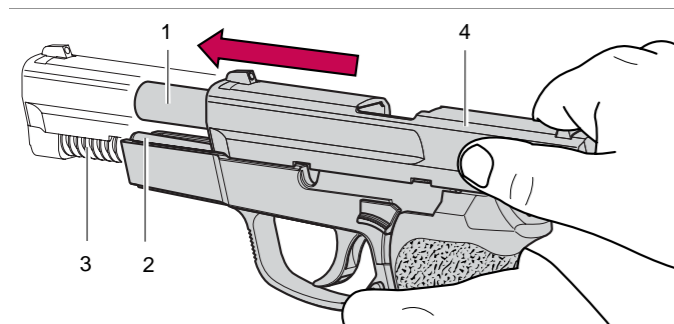

Fig. 10

6. Now slip the complete assembly (slide **4**, barrel **1**, recoil spring **3** and recoil spring guide **2**) forward and off the frame **15**.

Caution

▲ Recoil spring **3** is compressed. Uncontrolled removal of recoil spring guide **2** can cause it and the spring to jump away. When stripping, control decompression of the pre-loaded recoil spring **3** with your hand.

Procedure

7. Push the recoil spring guide **2** carefully forwards and to one side or lift off and remove the recoil spring **3** with the recoil spring guide **2** from the slide **4** (Fig. 11).

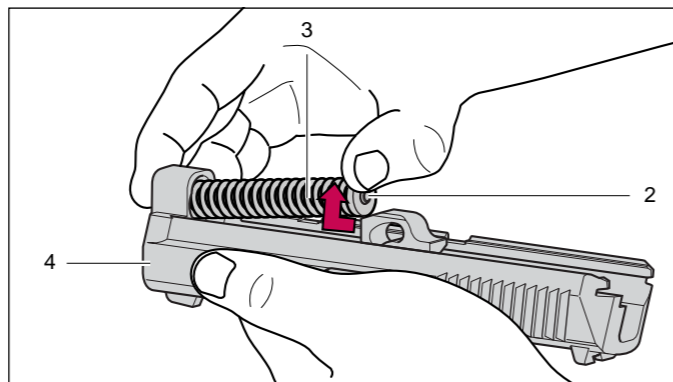

Fig. 11

8. Remove barrel **1** from slide **4** (Fig. 12).

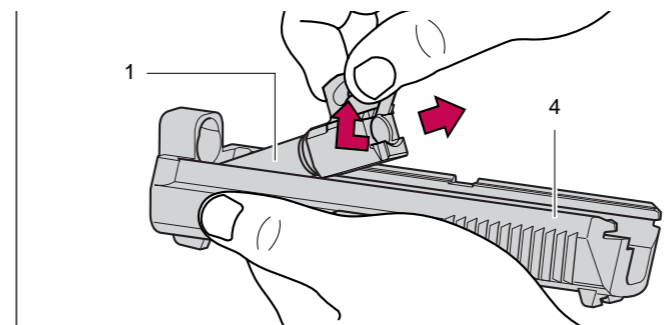

Fig. 12

Notice

▲ Do not remove the grip plate **45** (work step 9) unless the weapon is extremely dirty (water, sand, mud etc.)

9. Press the retaining lug **45a** in the well and remove the grip plate **45** (Fig. 13).

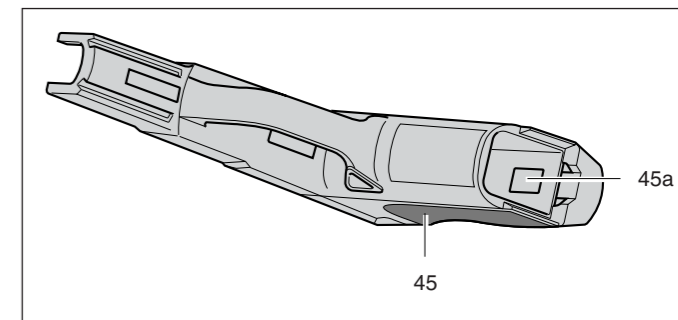

Fig. 13

Notice

▲ This level of stripping is sufficient to allow a thorough cleaning after shooting.

▲ Further dismantling of the pistol may only be carried out by qualified armourers and gunsmiths.

7.2 Cleaning the pistol



Notice

- ▲ Never clean barrel **1** from the muzzle end and do not use steel wire brush as it can destroy the smooth surface of the bore. Use a suitable cleaning rod and brush of matching calibre (see Sect. 12).
- ▲ Solvents can be harmful to the surface finish of the pistol. Read the manufacturer's warnings and indications before using solvents or cleansers.

Procedure

1. Lubricate the cleaning brush with gun oil and insert it into barrel **1** via the chamber. Use brush to carefully remove all powder residues and dirt in the barrel **1** and chamber.
2. Wipe powder residues and oil from the barrel bore and chamber with cleaning patches.
3. Clean external surfaces of barrel **1** with a brush dipped in gun oil.
4. Clean the metal guide in the frame **13**, the inside and outside surfaces of the slide **4**, the locking insert **14** and recoil spring **3** with a brush or rag. Then oil or grease with a cloth impregnated with gun oil or grease.
5. Lightly oil bores of barrel and chamber.
6. If the weapon is extremely dirty (water, sand, mud etc.), in addition to normal cleaning, the grip plate should be removed (see Sect. 7.1, Point 9). This permits thorough cleaning of the trigger mechanism.

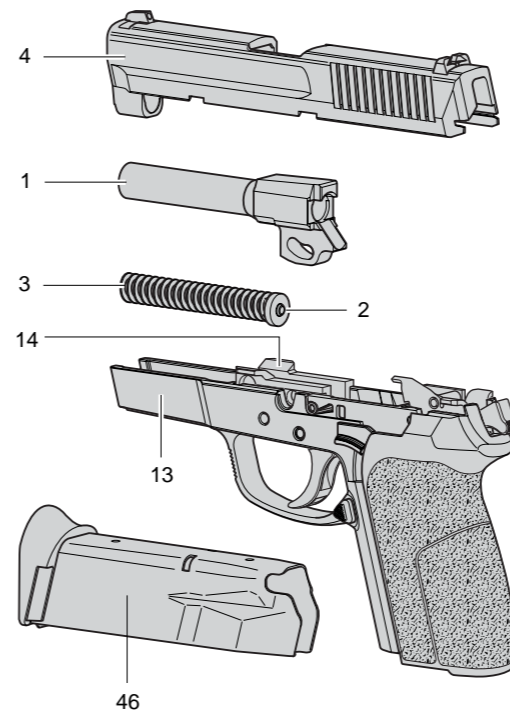

Fig. 14, Pistol dismantled for cleaning

7.3 Assembling the pistol

Procedure

1. Check that there is no foreign matter inside the pistol.
2. Push the grip plate back on from below until it notches home.
3. Place the barrel **1** with the control cam in the slide **4** from below.



Caution

- ▲ When recoil spring **3** is inserted into slide **4**, it becomes pre-loaded. If the recoil spring guide **2** is not carefully installed in slide **4**, it can fly out, together with the recoil spring **3**, and injure you or someone in your vicinity.
4. Insert recoil spring guide **2** with recoil spring **3** into slide **4**.
 5. Push the entire system onto the frame **13** from the front until it is correctly on rear side positioned.
 6. Push the slide catch lever **17** into position horizontally from the left until it rests against the slide **4**.

7. Hold the frame **13** with the right hand. Pull the slide **4** back with the left hand until the recess **4b** on the slide **4** coincides with the slide catch lever lug **17**. Press the slide catch lever **17** into position until it audibly notches home (Fig. 15).

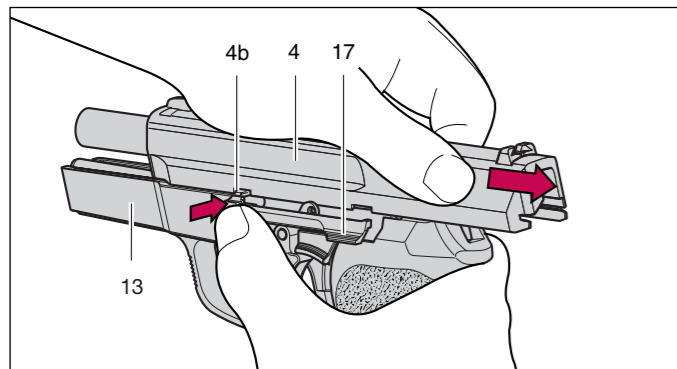

Fig. 15

8. Follow the slide **4** forwards with the hand.
9. Thumb down decocking lever **38**. (Not applicable for DAO pistols.)



Notice

- ▲ The pistol is unloaded and decocked.

7.4 Verification of functions



Notice

- ▲ Verification of functions must be conducted on the assembled pistol:

- to identify causes of malfunction,
- after completion of repairs
- and after each cleaning and assembly of the pistol.

Procedure

1. Remove the magazine and unload the pistol (see Sect. 5.8).
2. Check the elasticity of recoil spring **3** and the smoothness of the slide **4** action.
 - Draw back slide **4** to the stop and allow it to fly forward.
 - Check that slide **4** is impelled forward with sufficient energy and that it locks up.
 - Repeat the verification test.
3. Check the trigger mechanism (DA).
 - With hammer **29** decocked, pull trigger **19** through.
 - Check that hammer **29** cocks and that at the end of trigger travel, it strikes firmly forward and comes to rest in the safety intercept notch.
4. Check trigger travel and trigger interruption.
 - With hammer **29** decocked and trigger **19** pulled through, draw back slide **4** to the stop and release it.
 - Check that hammer **29** is restrained in its cocked position (trigger remains pulled through). (Not applicable to DAO pistols.)
5. Check simple trigger function (SA).
 - Release trigger **19**.
 - Check that trigger bar **22** reengages and whether hammer **29** drops when the trigger is pulled again.
6. Check function of decocking lever **38** and safety intercept notch on hammer **29**.
 - Cock hammer **29** and decock it with decocking lever **38** without touching trigger **19**. (Not applicable to DAO pistols.)
 - Check that hammer **29** is arrested in the safety intercept notch before reaching its forward end position and trigger **19** is guided to the rest position.
7. Check slide catch lever **17**.
 - Insert empty magazine, draw back slide **4** to the stop and release it.
 - Check that slide **4** remains caught in its rearmost position.
 - Actuate slide catch lever **17**.
 - Check that slide **4** is released and impelled forward with sufficient energy.
 - Actuate decocking lever **38**. (Not applicable to DAO pistols.)
 - Remove magazine.
8. Inspect magazine.
 - Check condition of magazine tube **46** for signs of damage or dirt (lips and floorplate).
 - Check that magazine floorplate is properly secured.
 - Check free movement and spring action of feeder **49**.

- Check smooth insertion of magazine into frame **13**.
 - Check magazine catch **24** for clean engagement and release.
9. Inspect external appearance of the pistol.
- Check front sight **5**, rear sight **6**, grip plate **45** for damage and dirt.
 - Check that front sight **5**, rear sight **6** and grip plate **45** are firmly secured.
10. Verification of numbered components.
- Check that serial numbers of barrel **1**, slide **4** and frame **13** correspond.

7.5 Care of the pistol



Notice

- ▲ Always keep your pistol in immaculate condition and in good working order.
- ▲ Always clean your pistol after use.
- ▲ Never modify or repair parts of your pistol yourself.
- ▲ Have your pistol checked once every 12 months by a qualified gunsmith or armourer because defects, wear, corrosion, etc. are not always visible from the outside.
- ▲ For repairs or service work, however, we recommend that you return your pistol to the manufacturer who always holds a full range of replacement parts in stock.
- ▲ If you order spare parts without returning the pistol, you are responsible for ordering the correct part and its correct fitting by a qualified gunsmith or armourer.



Caution

- ▲ The manufacturer and importer cannot be held liable for faults in the pistol or malfunctions if the pistol has been modified or non-original parts have been fitted by third parties.

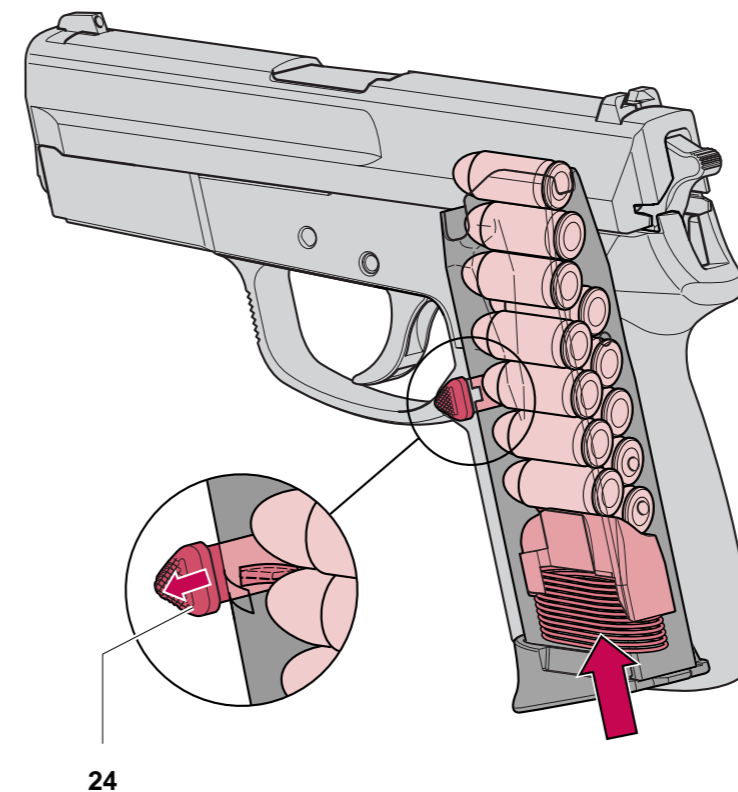

Fig. 16, Pistol with magazine inserted

8 Function of the Pistol



Warning

- ▲ The description of functions is not a set of instructions covering the use, care or repair of the pistol. Any manipulations on the pistol based on the following description of functions are strictly prohibited.

8.1 Function sequence when loading

8.1.1 Magazine inserted

- Full magazine is inserted up to the stop in the frame.
- Magazine catch **24** has engaged the magazine.

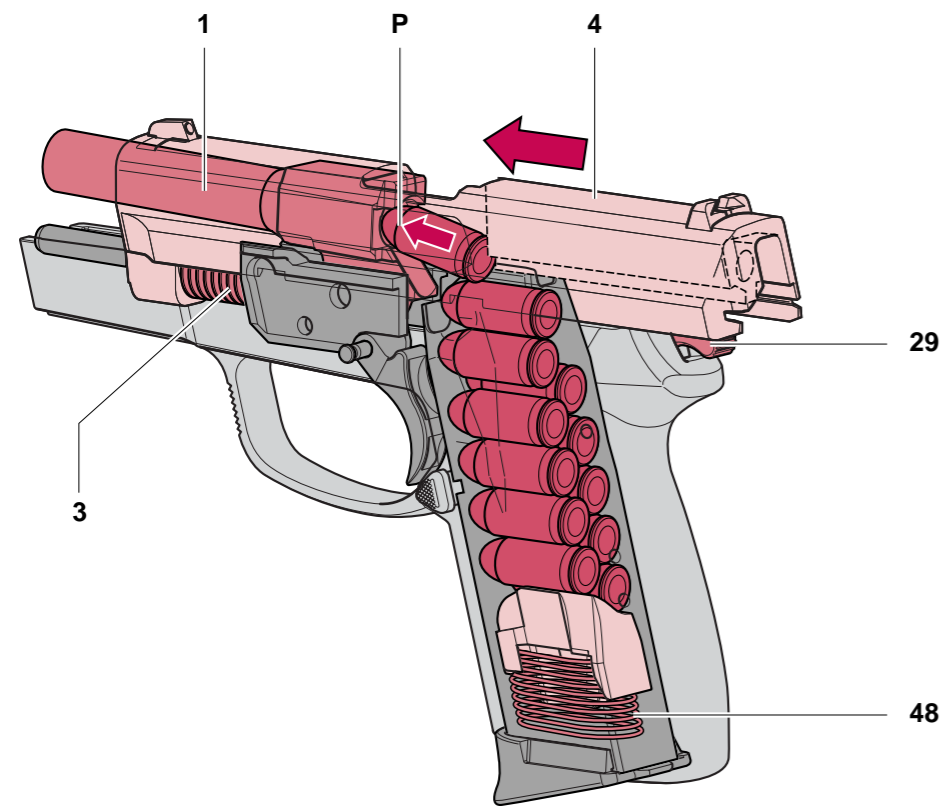

8.1.2 Function sequence when loading

- As slide **4** is drawn back, the hammer **29** is cocked.
- Top round **P** is thrust up into the feeding position by magazine spring **48**.
- When slide **4** is released, it is impelled forward by the compressed recoil spring **3**.
- Round **P** is chambered in the barrel **1** by slide **4**.

The pistol is ready to fire. Hammer **29** is cocked * and can be decocked * with decocking lever **38**.

* Not applicable to DAO pistols.

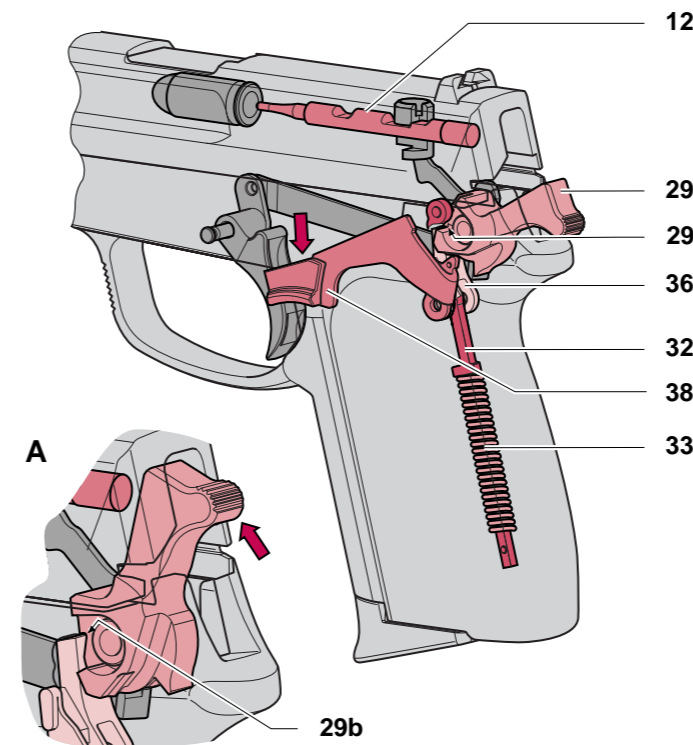

8.2 Function sequence when decocking *

8.2.1 Hammer decocking *

- Decocking lever * **38** is thumbed down.
- Sear **36** lifts out of register with the SA notch **29a** of hammer **29**.
- Hammer **29** is released and pivoted forward by hammer strut **32** and main spring **33**.
- Hammer **29** engages decocking lever **38** and accompanies this until being intercepted in the safety notch **29b** by sear **36** (see Fig. A).
- When decocking lever **38** is released, it returns to the rest position.

During and after decocking, firing pin **12** remains locked. Safety intercept notch **29b** is the rest position of hammer **29**.

* Not applicable to DAO pistols.

Fig. 17, Round being chambered

Fig. 18, Sear being pivoted out of SA notch

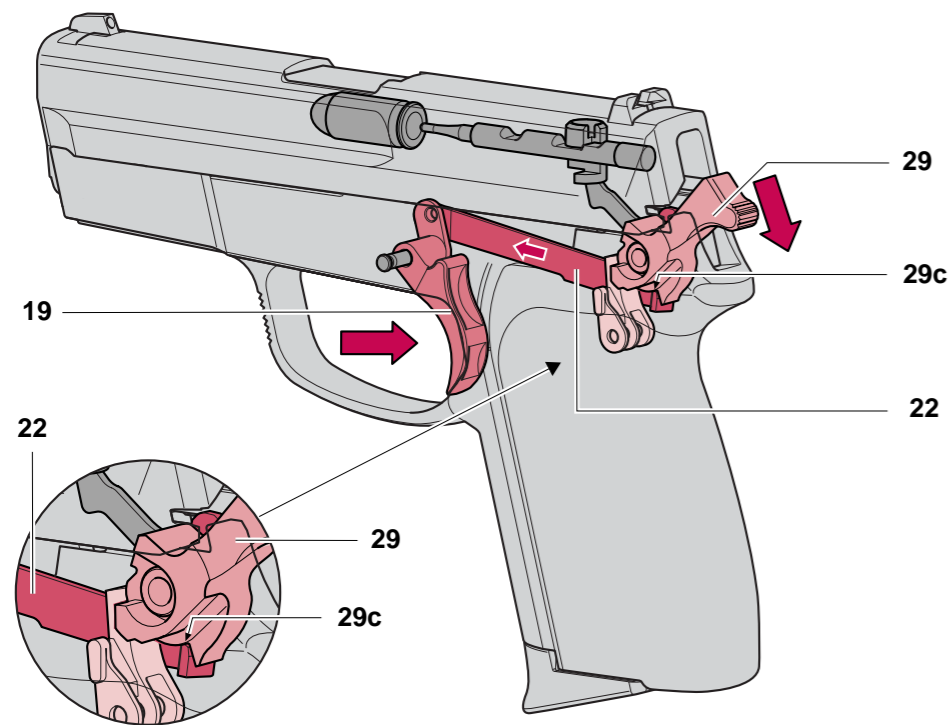

8.3 Function sequence when firing in "Double Action" mode



Notice

▲ Firing in "Single Action" mode, see Sect. 8.5.

8.3.1 Hammer cocking with the trigger

- Trigger 19 is pulled.
- Trigger bar 22 cocks hammer 29 via double action notch 29c.

Fig. 19, Hammer being cocked via trigger action

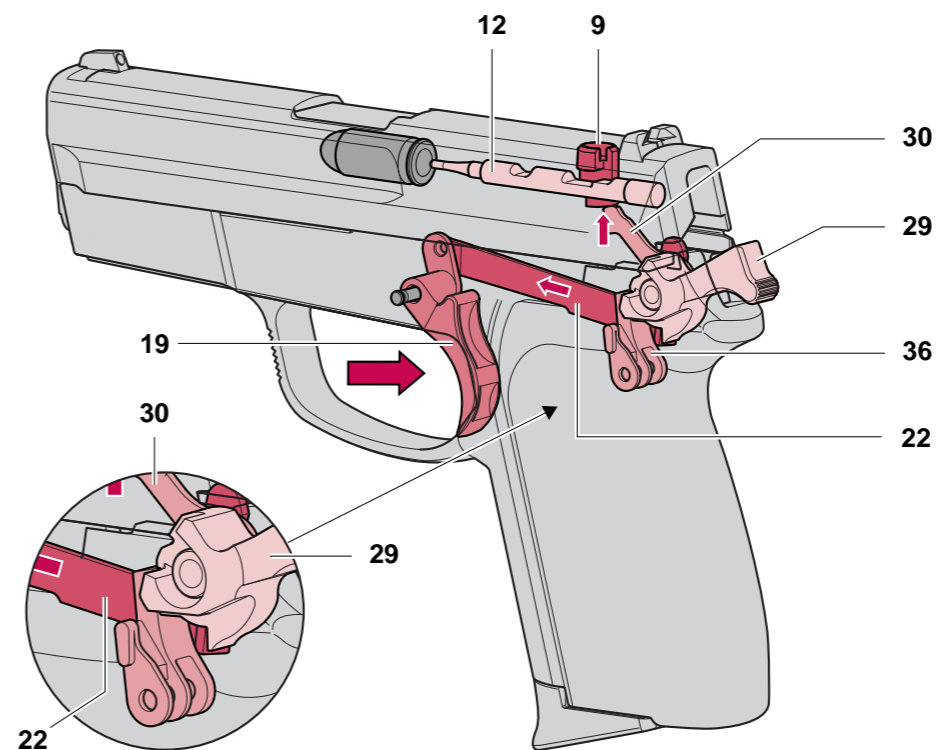

8.3.2 Firing the pistol

- Trigger 19 is pulled up to the stop.
- Trigger bar 22 pivots safety lever 30 and sear 36 forwards. Safety lever 30 raises safety lock 9, thereby liberating firing pin 12.
- The control cam of the action casing 26 guides the trigger bar 22 away from the double action notch (DA notch) of the hammer 29.
- Hammer 29 is released.

Fig. 20, Hammer is released "Double Action"

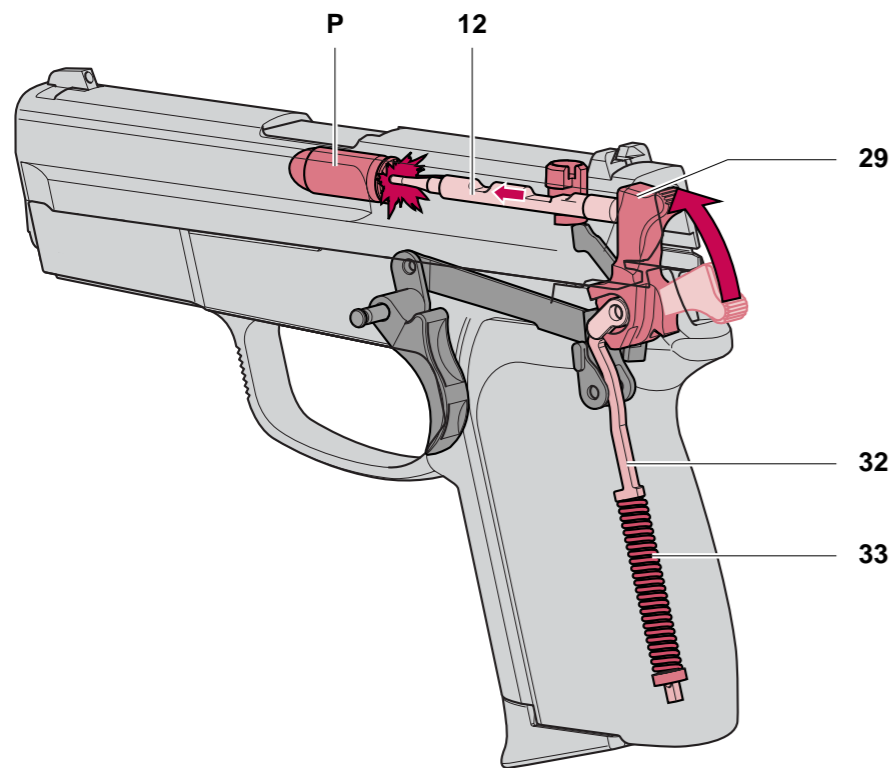

8.3.3 Function sequence at shot discharge

- Hammer **29** is released.
- Via hammer strut **32**, main-spring **33** thrusts hammer **29** upwards.
- Hammer **29** strikes firing pin **12**.
- Firing pin **12** impacts against the primer of round **P**.

Fig. 21, Round is discharged

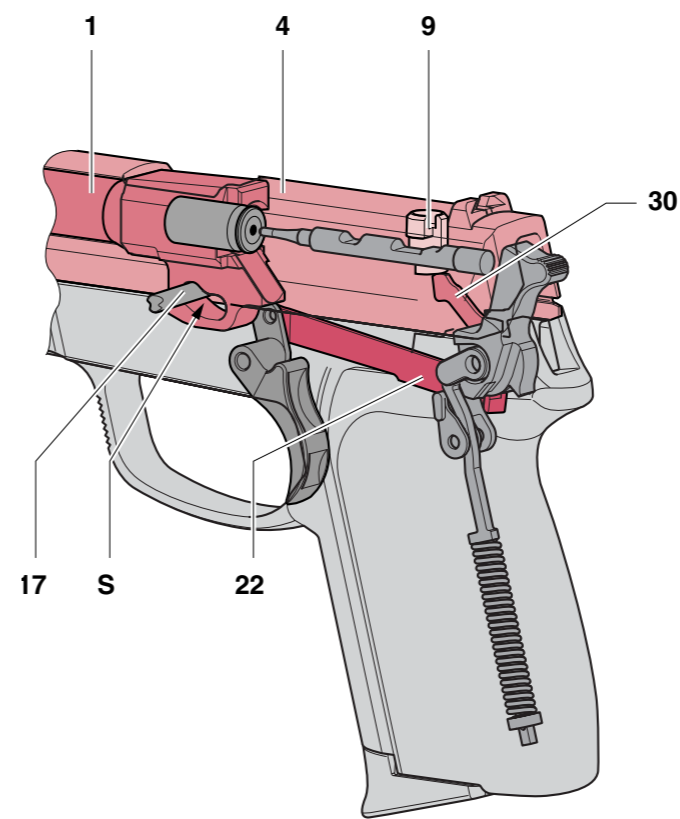

8.4 Function sequence at case ejection and automatic reloading

8.4.1 Unlocking

- Blowback reaction generated at discharge thrusts slide **4** to the rear.
- This separates safety lever **30** and safety lock **9**. Firing pin lock is effective again.
- Slide **4** depresses trigger bar **22**, thereby disconnecting trigger bar **22** from safety lever **30**.
- The barrel **1** must be swung downwards to release by means of the control cam **S** in conjunction with the slide catch lever pivot **17**.

Safety in the case of incompletely closed slide position

If slide **4** is not in its fully locked final position, the register between safety lever **30** and safety lock **9** is cancelled. Also, trigger bar **22** is depressed by slide **4**, thereby interrupting the remaining trigger functions.

Fig. 22, Barrel is tilted down and arrested

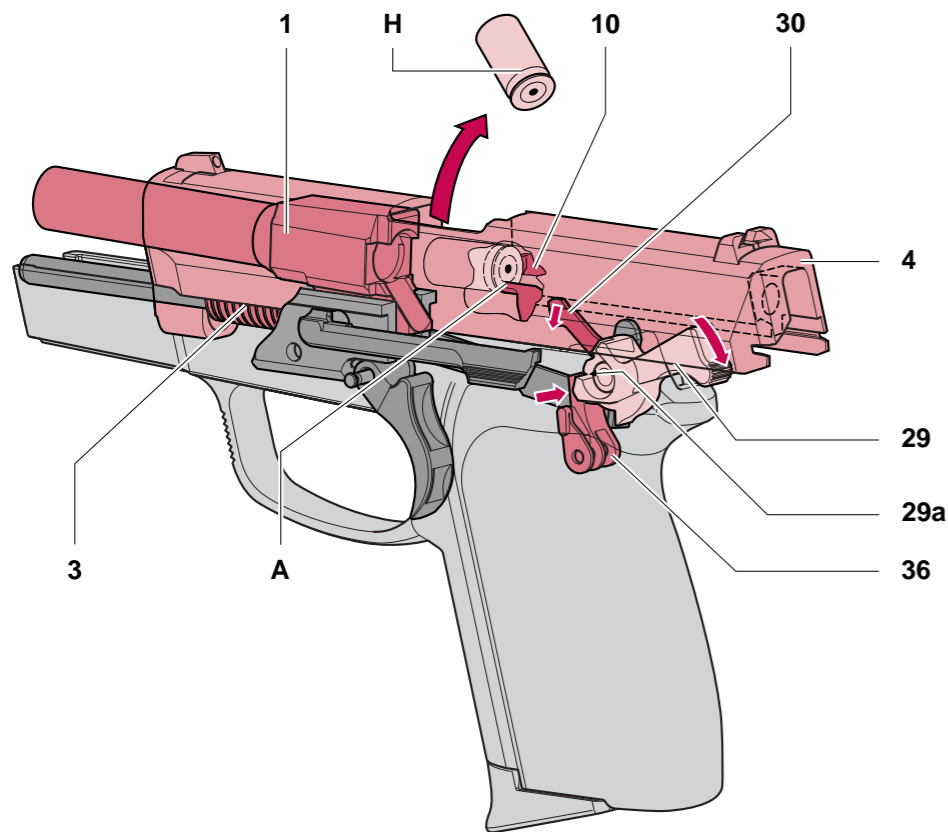

8.4.2 Function sequence at case ejection and hammer cocking

- Sear spring presses sear **36** and safety lever **30** to their initial positions.
- Empty case **H** is extracted by extractor claw **10** and, upon striking the ejector **A**, is ejected.
- As slide **4** recoils up to its stop, it cocks hammer **29** and is then caught in the SA notch **29a** by sear **36**.*
- Slide **4** is propelled forward through pressure of the cocked recoil spring **3** and the next round is fed (see Sect. 8.1.2). Barrel **1** locks up with slide **4** again.

The pistol is ready to fire.
Hammer **29** is cocked.*

* Not applicable to DAO pistols.

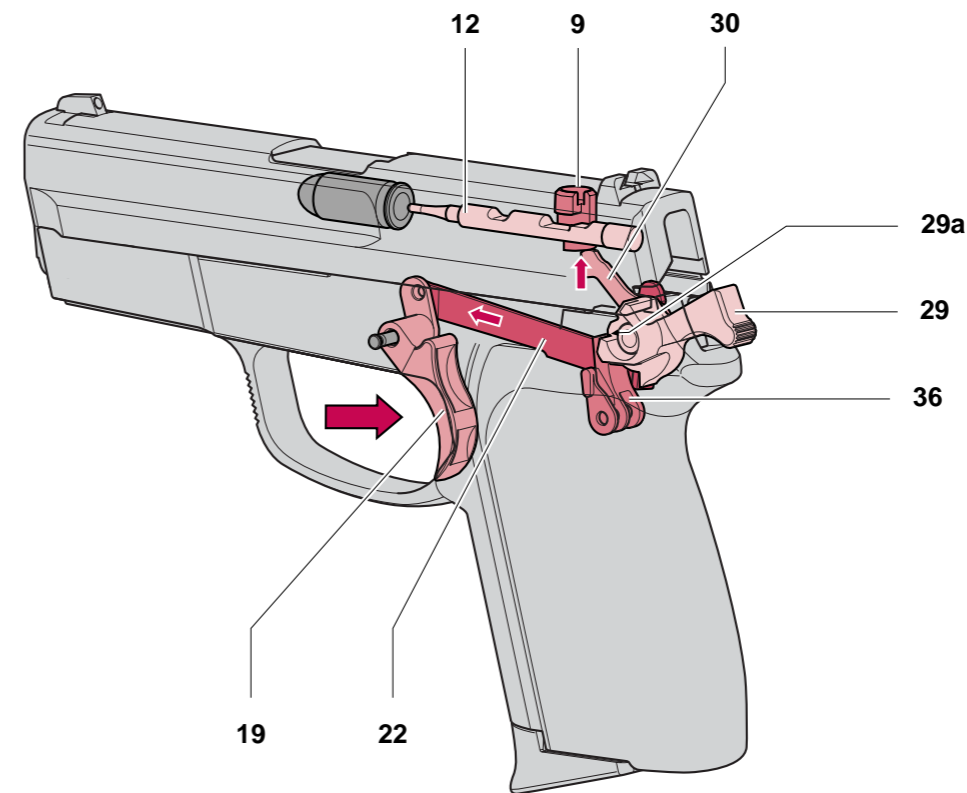

8.5 Function sequence when firing in "Single Action" mode *

Firing in "Single Action" mode

- Trigger **19** is pulled.
- Trigger bar **22** pivots safety lever **30** forwards, which raises safety lock **9**, thereby liberating firing pin **12**.
- At the same time, safety lever **30** disengages sear **36** from the SA notch **29a** of hammer **29**, thereby releasing hammer **29**.
- The round is discharged (see Sect. 8.3.3).

* Not applicable to DAO pistols.

Fig. 23, Case being ejected

Fig. 24, Hammer is released "Single Action"

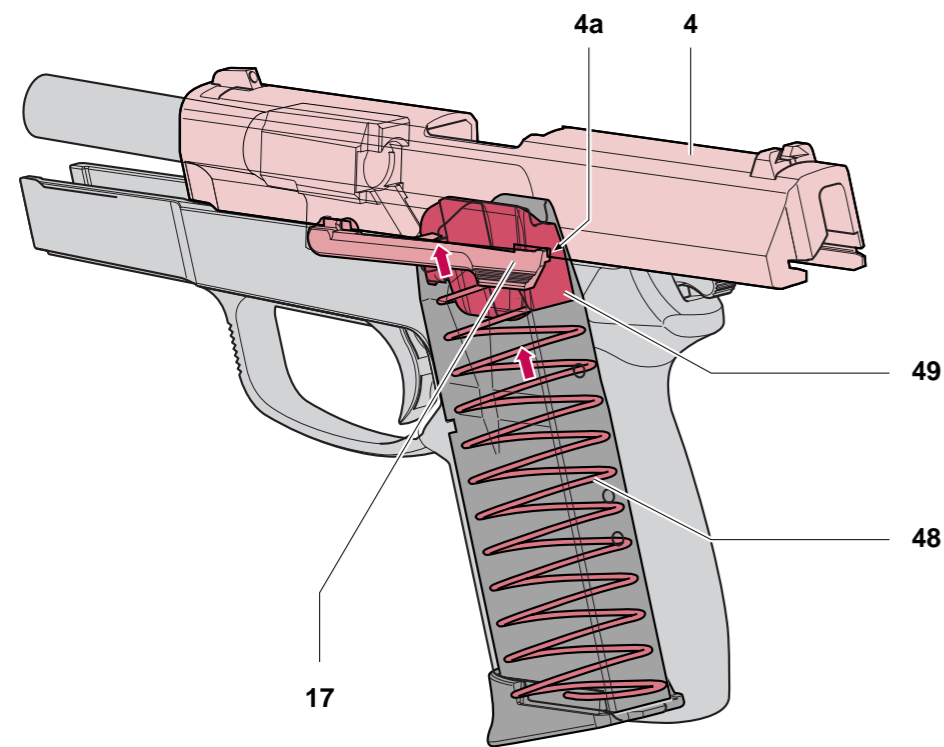

8.6 Function sequence after discharge of last round

- Blowback reaction generated at discharge thrusts slide 4 to the rear stop.
- In the empty magazine, magazine spring 48 raises feeder 49 which also presses up slide catch lever 17. Slide catch lever 17 registers in notch 4a of slide 4.
- Slide 4 is arrested in its open position.

Fig. 25, When magazine is empty, slide is held open

9 Pistol Service and Repairs

9.1 Cause and correction of malfunctions

Pistol maintenance (cleaning and inspection) according to the instructions can prevent malfunctions. Should, nevertheless, a malfunction occur during shooting, proceed as follows:



▲ Hold pistol pointed in the firing direction (safe direction) and keep your finger off trigger 19 while you carry out the operations described in the following.

1. Remove and safeguard the magazine.
2. Draw back slide 4 and arrest it in the open position by thumbing up slide catch lever 17.
3. Verify (visually or with a tool) that there is no bullet, round, case or foreign body in the barrel bore or chamber (see Fig. 3, page GB 10). If a projectile is lodged in the bore, strip the pistol (see Sect. 7.1) and have the blockage removed with a suitable tool by a qualified gunsmith.
4. Remove all rounds, cases or foreign bodies. Clean, lubricate and assemble the pistol (see Sect. 7.2/7.3).
5. Have the pistol inspected by an armorer or gunsmith.

Assembly/Malfunction	Potential Cause	Potential Remedy
Ammunition feed: No round chambered.	Magazine not properly inserted, deformed or dirty.	Insert magazine properly or replace it.
Slide: Slide does not close properly.	Pistol or rounds dirty or too heavily greased.	Strip, clean and lubricate pistol (see Sect. 7.1-7.3); clean or replace ammunition.
	Pistol defective.	Repair by manufacturer.

Service and Repairs

Assembly/Malfunction	Potential Cause	Potential Remedy
Case ejection: Spent case sticks in chamber or jams in ejection port.	Recoil insufficient because of fouling.	Strip, clean and lubricate pistol (see Sect. 7.1–7.3)
	Underloaded ammunition.	Replace ammunition.
	Pistol defective.	Repair by manufacturer.
Misfire: Hammer strikes, but no discharge.	Firing pin sticking in its guide.	Strip, clean and lubricate pistol (see Sect. 7.1–7.3). Have pistol checked by armorer.
	Defective ammunition.	Manually cycle slide to chamber new round.
	Pistol defective.	Repair by manufacturer.

9.2 Safekeeping and storage of the pistol



Warning

- ▲ Always store your pistol unloaded and in cleaned condition.
- ▲ Store your pistol separate from its ammunition and under lock and key. The pistol and ammunition must not be accessible to children and other inexperienced or unauthorized persons.

9.3 Shipping the pistol



Warning

- ▲ Familiarize yourself fully with local legislation governing the shipping and transportation of firearms.
1. Check the pistol to ensure that it is unloaded and decocked.

Service and Repairs

2. Pack the pistol well (if possible in its original packaging) to prevent damage in transit. To prevent the pistol being recognized as such during shipping, wrap the original packaging in a second outer layer. Do not include carrying cases, telescopic sights, scope mounts or other accessories in the shipment.
3. Enclose a letter stating the following:
 - your full name
 - your full address (mention street, not P.O. Box)
 - your daytime telephone number
 - model and serial numbers of the pistol
 - detailed description of the problem encountered or the service work to be performed.
4. Send the pistol properly insured and carriage-paid (packages without correct postage will not be accepted) to:
 1. the sales outlet from which you purchased the pistol
 2. the local appointed SIG dealer
 3. the SIG agent (importer) for your country
 4. if there is no local appointed SIG dealer or SIG agent in your country, to one of the following addresses:

Swiss Arms Neuhausen (SAN)
z.H. Service-Abteilung
CH-8212 Neuhausen am Rheinfall/Switzerland
Phone (052) 674 65 65
Fax (052) 674 64 18

J. P. Sauer & Sohn GmbH
z.H. Service-Abteilung
Sauerstrasse 2–6
D-24340 Eckernförde/Germany
Phone (04351) 47 10
Fax (04351) 47 11 60

HÄMMERLI AG
z.H. Service-Abteilung
Seonerstrasse 37
CH-5600 Lenzburg/Switzerland
Phone (062) 888 22 22
Fax (062) 888 22 00

SIG Arms Inc.
Service Department
Corporate Park, Industrial Drive
Exeter NH 03833/USA
Phone (001) 603-772-2302
Fax (001) 603-772-9082

10 Training Aids and Product Line

The accessories and training aids in the following list are not standard delivery with the pistol, but can be ordered from any of the addresses shown in Sect. 9.3.

10.1 Training aids*

- Working models
- Cutaway models
- Training charts
- Slides
- Overhead slides
- Videos for armourers
- Product videos

* on request

10.2 Product line

- Pistols for government agencies and the military
- Sport pistols
- Match pistols
- Assault rifles
- Precision rifles (sniper)
- Hunting rifles
- Target rifles
- Air rifles
- Accessories for pistols and rifles

11 Disposal

- Strictly observe any current national legislation governing the disposal of handguns.
- Provided this is not contrary to current national legislation, we recommend shipping the pistol to one of the addresses listed under Sect. 9.3 for disposal.
- When shipping the pistol, strictly observe the instructions listed under Sect. 9.3.

12.1 Technical Specifications SPC 2009

	SPC 2009	SP 2009	SP 2340
Calibre	9 mm Para	9 mm Para	.40 S&W / .357 SIG
Length, overall	180 mm	187 mm	187 mm
Height, overall	134 mm	144 mm	144 mm
Width, overall	34 mm	34 mm	34 mm
Barrel length	91 mm	98 mm	98 mm
Rifling lead	250 mm	250 mm	380 mm / 406 mm
No. of grooves	6	6	6
Sight base	150 mm	150 mm	150 mm
Weight, excl. magazine	700 g	715 g	765 g / 775 g
Magazine weight, empty	87 g	87 g	90 g
Trigger pool DAO/DA, approx.	45-60 N (4,5-6 kg)	45-60 N (4,5-6 kg)	45-60 N (4,5-6 kg)
Trigger pool SA, approx.	20-25 N (2-2,5 kg)	20-25 N (2-2,5 kg)	20-25 N (2-2,5 kg)
Magazine capacity/Rounds	15	15	12

Accessories

- Spare magazines
- Cleaning kit
- Rear and front sight key
- SIGLITE sights
- Micrometer rear sight
- Grip plates small, large
- Holster
- Short trigger

Standard version

- SA/DA trigger system
- Slide, black
- Grip plate, small

Alternative versions

- DAO trigger system
- Slide in rustproof material (stainless, bright)
- Barrel in rustproof material (stainless)

 **Notice**

▲ For the accompanying figure to the list, see page GB 37.

Essential information when ordering spare parts

- Pistol model (calibre, designation)
- Pistol serial number
- Item number and index
- Part designation

Index explanation

- C = DAO pistol models
- * = not for DAO pistols

 **Warning**

▲ Never install a standard hammer **29** in a DAO pistol.

Item	Designation
1	Barrel
2	Recoil spring guide
3	Recoil spring
4	Slide
5	Front sight 05/06/07/08/09/10
6	Rear sight 04/05/06/07/08/09/10
7	Bolt firing pin
8	Safety lock spring
9	Safety lock
10	Extractor
11	Firing pin spring
12	Firing pin
13	Frame
14	Locking insert
15	Axial locking spring
16	Locking insert pivot

Item	Designation
17	Slide catch lever
18	Slide catch lever spring
19	Trigger
20	Trigger spring
21	Trigger pivot
22	Trigger bar
23	Magazine catch spring
24	Magazine catch
25	Magazine catch lock
26	Action casing
27	Drive lever
28	Reset spring
29, 29 C	Hammer
30	Safety lever
31	Hammer pivot pin
32	Hammer strut
33	Main spring

Item	Designation
34	Hammer strut bushing
35	Hammer strut pin
36	Sear
37	Sear spring
38 *	Decocking lever
39	Pivot, sear and decocking pin
40 *	Decocking lever spring
41	Pusher spring
42 *	Trigger bar pusher
43	Upper action casing pin
44	Lower action casing pin
45	Grip plate
46	Magazine tube
47	Floorplate insert
48	Magazine spring
49	Feeder
50	Magazine floorplate

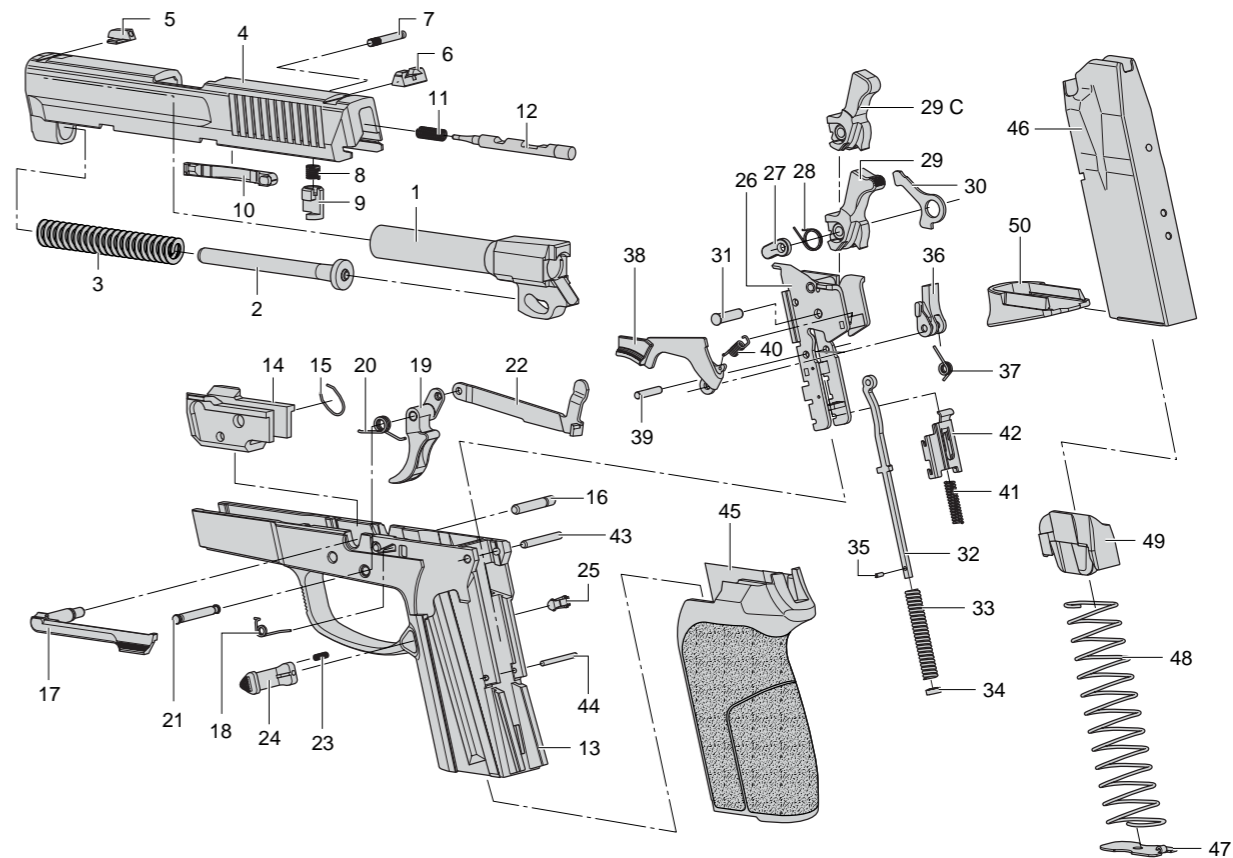

/ Swiss Arms Neuhausen (SAN)

Industrieplatz
CH-8212 Neuhausen am Rheinfall
Schweiz
Telefon +41 52 674 65 65
Telefax +41 52 674 64 18
Internet www.sigarms.ch

/ SIG Arms Inc.

Corporate Park
Industrial Drive
Exeter NH 03833
USA
Telefon +1 603 772 23 02
Telefax +1 603 772 90 82

/ J. P. Sauer & Sohn GmbH

Sauerstrasse 2-6
D-24340 Eckernförde
Deutschland
Telefon +49 4351 47 10
Telefax +49 4351 47 11 60
Internet www.sauer-waffen.de

/ HÄMMERLI AG

Seonerstrasse 37
CH-5600 Lenzburg
Schweiz
Telefon +41 62 888 22 22
Telefax +41 62 888 22 00